

**AGENDA
REGULAR MEETING
BOROUGH OF SEA BRIGHT**

JULY 16, 2024

SEA BRIGHT, NEW JERSEY

TO ATTEND THIS MEETING REMOTELY PLEASE USE THE FOLLOWING:

<https://meet.goto.com/160753173>

OR DIAL: (646) 749-3122

Access Code: 160-753-173

CALL MEETING TO ORDER: 7:00pm

PLEDGE OF ALLEGIANCE

COMPLIANCE STATEMENT (N.J.S.A. 10:4-18)

Good Evening Ladies and Gentlemen. This Meeting Is Now Called To Order: In Line with The Borough of Sea Bright's Longstanding Policy of Open Government, and in Compliance with the "Open Public Meetings Act" I Wish to Advise You That Adequate Notice of This Regularly Scheduled Meeting Was Sent to the Asbury Park Press and other local newspapers on January 8, 2024. In each instance, the Date, Time, And Location of This Meeting Were Provided in The Notice. This Meeting Is Open To The Public."

ROLL CALL:

Councilmember(s) BIEBER ____ CATALANO ____ GORMAN ____

KEELER ____ LAMIA ____ LECKSTEIN ____

Mayor KELLY ____

EXECUTIVE SESSION

Councilmember offered a motion to enter into Closed Session; seconded by
Councilmember

Resolution to discuss: Litigation

Roll Call: Bieber____ Catalano____ Gorman____ Keeler____ Lamia____ Leckstein____

RESUME MEETING

Councilmember offered a motion to enter back into the regular meeting;
seconded by Councilmember

Roll Call: Bieber____ Catalano____ Gorman____ Keeler____ Lamia____ Leckstein____

MOMENT OF SILENCE FOR THE FOLLOWING MEMBERS OF THE SEA BRIGHT COMMUNITY WHO PASSED AWAY:

**Herbert M. Holzberg
Thomas Liptak**

PROCLAMATION: **RECOGNIZING SEA BRIGHT FIRE RESCUE ON ACHIEVING PUBLIC PROTECTION CLASSIFICATION 02 FROM INSURANCE SERVICES OFFICE, INC. (ISO)**

REMARKS FROM THE AUDIENCE (limited to 3 minutes)

The Public Comment portion of this meeting allows members of the audience to bring their concerns or comments to the Mayor and Council's attention. Pursuant to Borough Ordinance 3-2011, a member of the public who wishes to speak shall give his/her name and address for the record and may have up to three minutes to state his/her comments to the Mayor and Council as a Body. If additional time or information is requested, an appointment can be made with the Administrator's office during regular business hours.

PRESENTATION AND PUBLIC HEARING:

SUBMISSION OF APPLICATION TO THE MONMOUTH COUNTY OFFICE OF COMMUNITY DEVELOPMENT FOR A COMMUNITY DEVELOPMENT BLOCK GRANT ADA BATHROOM IMPROVEMENTS AT COMMUNITY CENTER

Councilmember _____ offered a motion to open the public hearing on the Community Development Block Grant Application; seconded by Councilmember _____

Roll Call: Bieber____ Catalano____ Gorman____ Keeler____ Lamia____ Leckstein____

Public Hearing

Councilmember _____ offered a motion to close the public hearing on the Community Development Block Grant Application; seconded by Councilmember _____

Roll Call: Bieber____ Catalano____ Gorman____ Keeler____ Lamia____ Leckstein____

CONSENT AGENDA

Councilmember _____ offered a motion to approve the items that are considered routine in nature under the consent agenda; seconded by Councilmember _____

Minutes

06-12-2024	Workshop Meeting
06-12-2024	Executive Session
06-18-2024	Regular Meeting
06-18-2024	Executive Session
06-26-2024	Special Meeting

Resolutions:

- | | |
|---------------------|---|
| No. 132-2024 | Accept the Performance Guarantee(s) for Block 13, Lot 37 – 1106 Ocean Avenue William A.G. Inc. |
| No. 133-2024 | Authorizing Agreement with JNM Holdings, Inc. for use of Parking Lot at 1139 Ocean Avenue – Block 19, Lots 2 & 2.01 for the 2024 Summer Season |
| No. 134-2024 | Authorizing Community Development Block Grant Application for ADA Bathroom Improvements in the Borough Community Center |
| No. 135-2024 | Authorizing Grant Application to NJDOT For Fiscal Year 2025 |
| No. 136-2024 | Rescinding Special Condition on the Alcoholic Beverage License of Donovan’s Reef Inc. for the 2024-2025 License Term |
| No. 137-2024 | Grace Period Extension for Payment of 3rd Quarter 2024 Taxes |
| No. 138-2024 | Refund of Payment Error Junior Lifeguard Program |
| No. 139-2024 | Authorizing Display of Fireworks at Sands Beach Club- August 20, 2024 |
| No. 140-2024 | Chapter 159 Budget Amendment State of New Jersey FY2024 Local Recreation Improvement Grant |
| No. 141-2024 | Authorizing Receipt of Bids Solid Waste and Recyclable Materials Collection Service |

No. 142-2024 Authorizing Receipt of Bids for the DPW Building on River Street

**No. 143-2024 Setting Bid Threshold and Appointing a Qualified Purchasing Agent
Borough of Sea Bright**

Roll Call: Bieber___ Catalano___ Gorman___ Keeler___ Lamia___ Leckstein___

ORDINANCE(s):

Public Hearing: Mayor Kelly to read the ordinance by title:

ORDINANCE NO. 11-2024
**AN ORDINANCE AMENDING AND SUPPLEMENTING CHAPTER 178, "SOLID
WASTE," OF THE CODE OF THE BOROUGH OF SEA BRIGHT
TO ADD THERETO A NEW ARTICLE VII, "BULK ITEMS."**

Councilmember _____ offered a motion to open the public hearing on Ordinance No. 11-2024; seconded by Councilmember _____

Roll Call: Bieber___ Catalano___ Gorman___ Keeler___ Lamia___ Leckstein___

Public Hearing (Ord. No. 11-2024)

Councilmember _____ offered a motion to close the public hearing on Ordinance No. 11-2024; seconded by Councilmember _____

Roll Call: Bieber___ Catalano___ Gorman___ Keeler___ Lamia___ Leckstein___

Councilmember _____ offered a motion to adopt Ordinance No. 11-2024 and advertise according to law; seconded by Councilmember _____

Roll Call: Bieber___ Catalano___ Gorman___ Keeler___ Lamia___ Leckstein___

Public Hearing: Mayor Kelly to read the ordinance by title:

ORDINANCE NO. 12-2024
**AN ORDINANCE OF THE BOROUGH OF SEA BRIGHT AMENDING AND SUPPLEMENTING
CHAPTER 130, "LAND USE", ARTICLE XVI, "STORMWATER CONTROL REGULATIONS" OF
THE CODE OF THE BOROUGH OF SEA BRIGHT**

**Monmouth County Planning Board Acknowledgement Received 07/01/24
Borough of Sea Bright Planning Board Acknowledgement Received 07/10/24**

Councilmember _____ offered a motion to open the public hearing on Ordinance No. 12-2024; seconded by Councilmember _____

Roll Call: Bieber___ Catalano___ Gorman___ Keeler___ Lamia___ Leckstein___

Public Hearing (Ord. No. 12-2024)

Councilmember _____ offered a motion to close the public hearing on Ordinance No. 12-2024; seconded by Councilmember _____

Roll Call: Bieber___ Catalano___ Gorman___ Keeler___ Lamia___ Leckstein___

Councilmember _____ offered a motion to adopt Ordinance No. 12-2024 and advertise according to law; seconded by Councilmember _____

Roll Call: Bieber___ Catalano___ Gorman___ Keeler___ Lamia___ Leckstein___

Introduction: Mayor Kelly to read the ordinance by title:

BOND ORDINANCE NO. 13-2024

BOND ORDINANCE PROVIDING AN APPROPRIATION OF \$260,000 FOR VARIOUS ROAD IMPROVEMENTS FOR AND BY THE BOROUGH OF SEA BRIGHT IN THE COUNTY OF MONMOUTH, NEW JERSEY AND, AUTHORIZING THE ISSUANCE OF \$50,500 BONDS OR NOTES OF THE BOROUGH FOR FINANCING PART OF THE APPROPRIATION.

Councilmember _____ offered a motion to introduce Ordinance No. 13-2024 for a public hearing to be held on August 20, 2024 and advertise according to law; seconded by Councilmember _____

Roll Call: Bieber___ Catalano___ Gorman___ Keeler___ Lamia___ Leckstein___

INDIVIDUAL ACTION/New Business:

Vouchers: \$ 858,803.79

Councilmember _____ offered a motion to approve the Voucher List dated July 16, 2024 as submitted by the Finance Manager; seconded by Councilmember _____

Roll Call: Bieber___ Catalano___ Gorman___ Keeler___ Lamia___ Leckstein___

MAYOR AND COUNCIL COMMENTS

ADJOURNMENT

Councilmember _____ offered a motion to adjourn the meeting; seconded by Councilmember _____

Roll Call: Bieber___ Catalano___ Gorman___ Keeler___ Lamia___ Leckstein___

Official Proclamation

WHEREAS, the Borough of Sea Bright recognizes Sea Bright Fire Rescue for achieving a Public Protection Classification 02 from Insurance Services Office, Inc. (ISO); and

WHEREAS, ISO collects and evaluates information from communities across the United States on their structure fire suppression capabilities and assigns a Public Protection Classification (PPC) grade to those communities; and

WHEREAS, Sea Bright Fire Rescue is one of only 31 departments in the State of New Jersey and one of only 2,004 departments nationwide to hold a Class 02 PPC rating; and

WHEREAS, we recognize the Sea Bright Fire Rescue for their commitment to the safety of our residents and visitors and commend them for this achievement; and

NOW, THEREFORE BE IT PROCLAIMED, that the Mayor and Borough Council of the Borough of Sea Bright, County of Monmouth, State of New Jersey do hereby congratulate, and thank Sea Bright Fire Rescue for achieving the ISO PPC Class 02 rating and appreciate all that the department and dedicated volunteers do for our community.

Mayor Brian P. Kelly
Borough of Sea Bright

July 16, 2024

Borough of Sea Bright

Community Center ADA Handicap Bathroom
Improvements

FY2025 Community Development Block Grant

Project Scope

- Improve accessibility for handicap individuals, including elderly and disabled person
- Currently, the community center lacks adequate accommodations for beach access bathrooms from the boardwalk.
- The goal of the project is to provide equal access to all members of our community to create an inclusive environment
- The project includes the development of ADA bathrooms (Beach Access), to be built at Sea Bright Community Center, which is located in Block 19, Lot 1 Along Ocean Avenue



Borough of Sea Bright
ADA Handicap Bathroom
Fiscal Year 2025
Community Development Block Grant Application

Proposed Performance

1. New ADA Beach Access Bathroom



LEON S. AVAKIAN, INC.
Consulting Engineers

788 Wayside Road
Neptune, New Jersey 07753

Office: (732) 922-9229 Fax: (732) 922-0044

Eligible Populations & Master Plan

- Under section 10 of the County Master plan, Municipal and Nonprofit projects are eligible to address
- Incorporating ADA compliant bathrooms align with several key principles and objectives of the Master plan
 - Accessibility and Inclusion – people of all abilities will be able to participate in public facilities, promoting social equity and inclusion
 - Community Health and Well-being – Sanitary facilities are essential for maintaining public health and well-being
 - Enhanced Public Infrastructure – compliant handicap bathroom contributes to the enhancement of public infrastructure within Monmouth County.
 - Tourism and Economic Development – Accessible facilities are crucial for attracting visitors and promoting tourism
 - Legal Compliance – Ensuring compliance with ADA standards not only upholds legal requirements but fosters a culture of respect for the rights and dignity of individuals with disabilities

Community Center History

- The Cecile F. Norton Community Center in Sea Bright, New Jersey, is a significant facility named in honor of Cecile F. Norton, a beloved member of the community known for her dedication and service.
- Beyond its administrative roles, the Municipal Building (Now Cecile F Norton Community Center) has served as a focal point for community activities and events. It plays a central role in the social and civic life of Sea Bright residents, hosting gatherings, celebrations, and town meetings.
- Cecile F. Norton was a beloved figure in Sea Bright, New Jersey, known for her significant contributions to the community. She dedicated much of her life to serving others and promoting the welfare of Sea Bright residents.
- The Community Building stands as a testament to the town's history, resilience in the face of natural challenges, and commitment to community service. It continues to be a significant landmark and hub of civic activity in Sea Bright, New Jersey.
- As the needs of the Borough evolve, the Community Center continues to provide for the needs of the residents.



Borough of Sea Bright
ADA Handicap Bathroom
Fiscal Year 2025
Community Development Block Grant Application

Proposed Performance

1. New ADA Beach Access Bathrooms



LEON S. AVAKIAN, INC.
Consulting Engineers

788 Wayside Road
Neptune, New Jersey 07753
Office: (732) 922-9229 Fax: (732) 922-0044

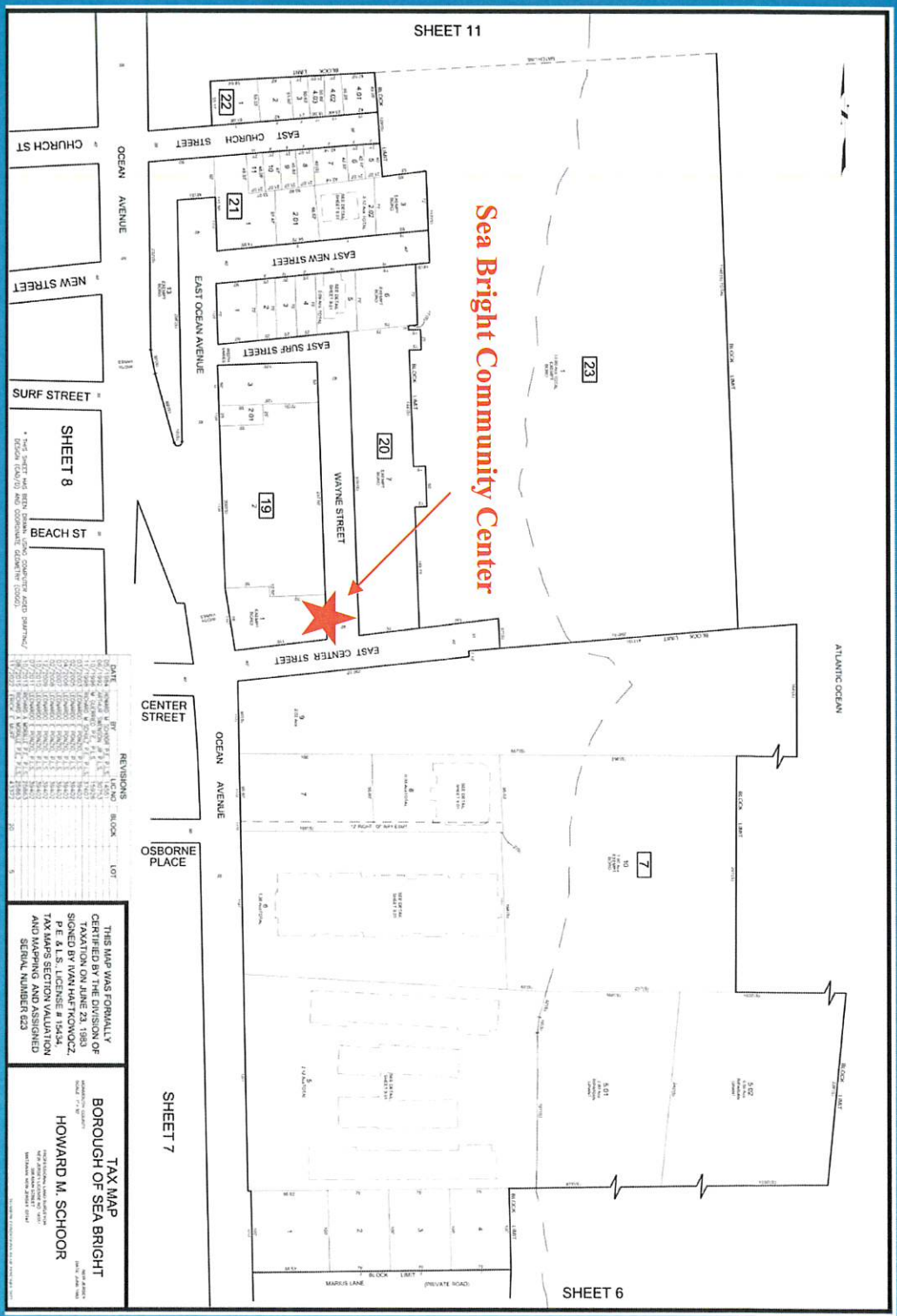

Sea Bright Community Center

DATE	REVISIONS	BLOCK	LOT
10/15/2024	1. Update lot numbers to match current zoning map.	101	1-10
08/15/2024	2. Correct street names and lot boundaries.	101	1-10
06/15/2024	3. Add new lots created by subdivision.	101	1-10
04/15/2024	4. Update zoning information for all lots.	101	1-10
02/15/2024	5. Review and verify all data for accuracy.	101	1-10

THIS MAP WAS FORMALLY CERTIFIED BY THE DIVISION OF TAXATION ON JUNE 23, 1983. SERIALIZED BY JAMES A. WALKER, P.E. A.L.S., LICENSE NUMBER 1000. TAX MAPS SECTION VALUATION AND MAPPING AND ASSIGNED SERIAL NUMBER 623.

TAX MAP
BOROUGH OF SEA BRIGHT
HOWARD M. SCHOOR
 Borough Engineer
 1000 Ocean Avenue, Sea Bright, NJ 08088
 Phone: 732-922-9229
 Fax: 732-922-0044

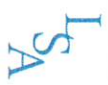

LEON S. AVAKIAN, INC.
 Consulting Engineers

788 Wayside Road
 Neptune, New Jersey 07753
 Office: (732) 922-9229 Fax: (732) 922-0044

Borough of Sea Bright

FY 2025

Lot 1 Block 19

Community Development Block Grant

Project Location

Community Center



Project Cost

July 9, 2024

LEON S. AVAKIAN, INC. *Consulting Engineers*

788 WAYSIDE ROAD • NEPTUNE, NEW JERSEY 07753

LEON S. AVAKIAN, P.E., P.L.S. (1950-2004)
 PETER R. AVAKIAN, P.E., P.L.S., P.P.
 MEHRVAR SHAHAI, P.E., P.P.
 MEGHON S. BLASH, P.E., P.P.
 ANDREW J. BROWN, P.E., P.P.
 GERALD J. FREDA, P.E., P.P.
 RICHARD PICATTOGI, L.L.A., P.P.
 JENNIFER C. BEAHM, P.P., AICP
 CHRISTINE L. BELL, P.P., AICP
 SAMUEL J. AVAKIAN, P.E.

ENGINEER'S ESTIMATE
 ADA HANDICAP BATHROOM IMPROVEMENTS
 IN THE
 BOROUGH OF SEA BRIGHT
 MONMOUTH COUNTY, NEW JERSEY

ITEM NO.	DESCRIPTION	QUANTITY	UNIT PRICE	AMOUNT	
1	Mobilization	1 LS	\$15,000.00	\$15,000.00	
2	Additional Excavation/ Footings	1 LS	\$20,000.00	\$20,000.00	
3	Foundation	1 LS	\$20,000.00	\$20,000.00	
4	Building Framing	1 LS	\$50,000.00	\$50,000.00	
5	Utilities to New Section of Building	1 LS	\$30,000.00	\$30,000.00	
6	Building Bathroom Amenities	1 LS	\$65,000.00	\$65,000.00	
CONSTRUCTION COST ESTIMATE				ITEMS 1-6	\$200,000.00

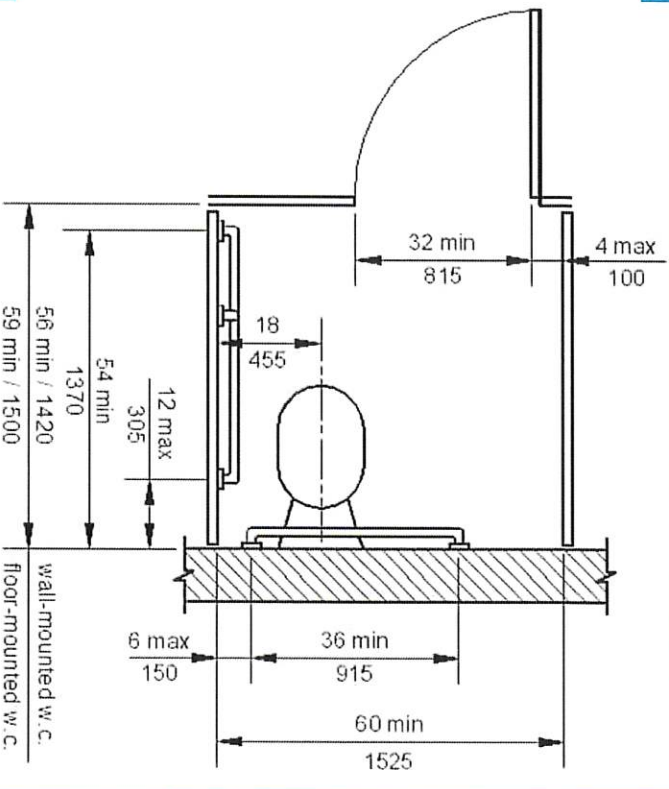
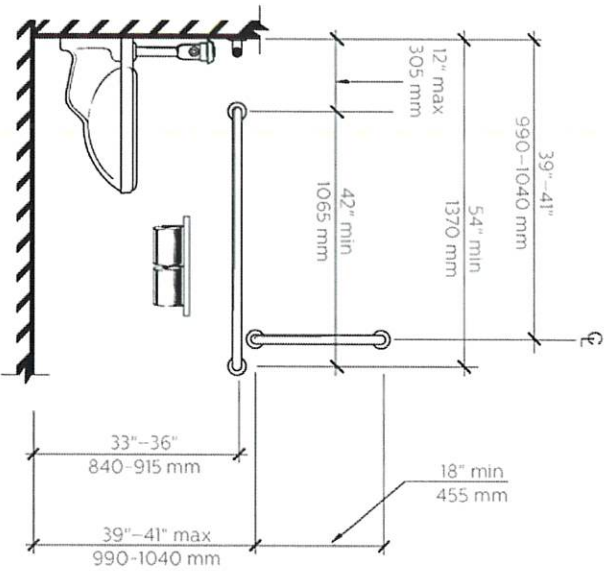

Borough of Sea Bright
ADA Handicap Bathroom
 Fiscal Year 2025
Community Development Block Grant Application

Proposed Performance

1. New ADA Beach Access Bathrooms

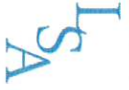

LEON S. AVAKIAN, INC.
 Consulting Engineers

788 Weyside Road
 Neptune, New Jersey 07753
 Office: (732) 922-9229 Fax: (732) 922-0044

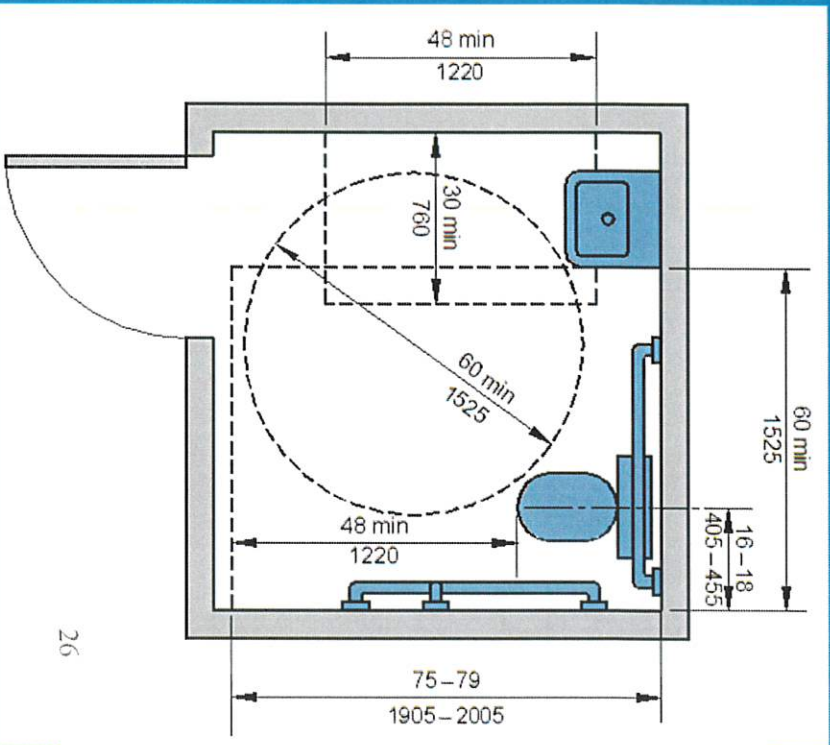

Wheelchair Accessible Toilet Compartment

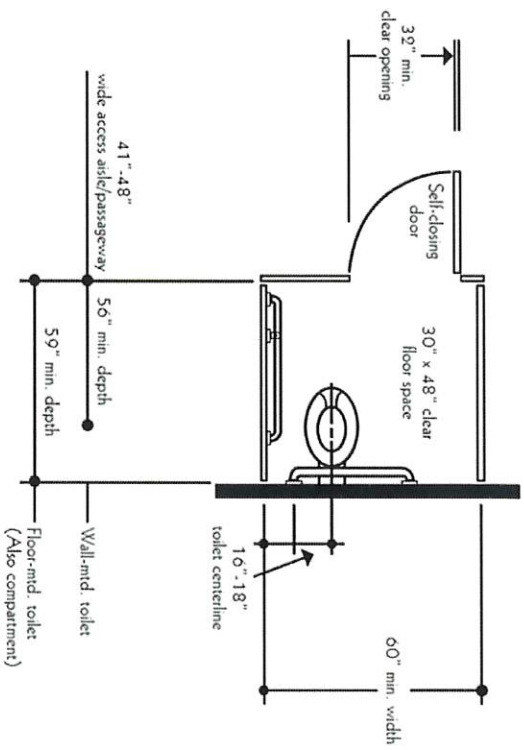

Borough of Sea Bright
ADA Handicap Bathroom
 Fiscal Year 2025
Community Development Block Grant Application

Proposed Performance

1. New ADA Beach Access Bathrooms



LEON S. AVAKIAN, INC.
 Consulting Engineers

788 Wayside Road
 Neptune, New Jersey 07753
 Office: (732) 922-9229 Fax: (732) 922-0044

Questions ??

July 9, 2024

LEON S. AVAKIAN, INC. *Consulting Engineers*

738 WAYSIDE ROAD - NEPTUNE, NEW JERSEY 07753

LEON S. AVAKIAN, P.E., P.L.S. (1953-2004)
PETER R. AVAKIAN, P.E., P.L.S., P.P.
MEHRVAR SHAFAI, P.E., P.P.
GREGORY S. BLASH, P.E., P.P.
LOUIS J. LOBOSCO, P.E., P.P.
GERALD J. FREDA, P.E., P.P.
RICHARD PICATAGI, L.L.A., P.P.
JENNIFER C. BEAHM, P.P., ACP
CHRISTINE L. BELL, P.P., ACP
SAMUEL J. AVAKIAN, P.E.

ENGINEER'S ESTIMATE
ADA HANDICAP BATHROOM IMPROVEMENTS
IN THE
BOROUGH OF SEA BRIGHT
MONMOUTH COUNTY, NEW JERSEY

ITEM NO.	DESCRIPTION	QUANTITY	UNIT	PRICE	AMOUNT
1	Mobilization	1 LS		\$15,000.00	\$15,000.00
2	Additional Excavation/ Footings	1 LS		\$20,000.00	\$20,000.00
3	Foundation	1 LS		\$20,000.00	\$20,000.00
4	Building Framing	1 LS		\$50,000.00	\$50,000.00
5	Utilities to New Section of Building	1 LS		\$30,000.00	\$30,000.00
6	Building Bathroom Amenities	1 LS		\$65,000.00	\$65,000.00
CONSTRUCTION COST ESTIMATE					\$200,000.00
ITEMS 1-6					

RESOLUTION NO. 132-2024
ACCEPT THE PERFORMANCE GUARANTEE(S) FOR
BLOCK 13, LOT 37 – 1106 OCEAN AVENUE
WILLIAM A.G. INC.

Councilmember introduced and offered for adoption the following Resolution; seconded
by Councilmember :

WHEREAS, the Borough of Sea Bright Planning Board has granted amended preliminary and final site plan approval with variance relief to William A.G. Inc., for a project on Block 13, Lot 37 also known as 1106 Ocean Avenue; and

WHEREAS, Planning Board Engineer, David Hoder of Hoder Associates Consulting Engineers, prepared a performance guarantee estimate dated May 23, 2024, for the project at 1106 Ocean Avenue; and

WHEREAS, in accordance with N.J.S.A. 40:55D-53, William A.G. Inc. posted said performance guarantees in the amount of \$2,973.60 (90% was paid in the form of a bond – Western Surety Company Bond No. 67089004 for \$2,676.24, and 10% in cash \$297.36) and the estimated engineering inspection fees in the amount of \$500.00 which were deposited with the Borough in accordance with the ordinances of the Borough of Sea Bright.

WHEREAS, the required Maintenance Bond in the amount of \$371.70 was received in cash and deposited with the Borough in accordance with the ordinances of the Borough of Sea Bright.

NOW, THEREFORE, BE IT RESOLVED by the Borough Council of the Borough of Sea Bright, County of Monmouth, State of New Jersey, that the requirements for entering into a developer's agreement are hereby waived; and

BE IT FURTHER RESOLVED that the performance guarantees as referenced above are hereby accepted.

BE IT FURTHER RESOLVED that a certified copy of this resolution be forwarded to the following:

1. Hoder Associates
2. Construction Official
3. Finance Manager
4. Planning Board Secretary
5. William A.G. Inc.

Roll Call: Bieber, Catalano, Gorman, Keeler, Lamia, Leckstein

July 16, 2024

CERTIFICATION

I, Christine Pfeiffer, Borough Clerk do hereby certify that the foregoing is a resolution adopted by the Borough Council of the Borough of Sea Bright, County of Monmouth State of New Jersey, at a Council Meeting held on July 16, 2024.

Christine Pfeiffer, Borough Clerk

RESOLUTION NO. 133-2024
AUTHORIZING AGREEMENT WITH JNM HOLDINGS, INC. FOR USE
OF PARKING LOT AT 1139 OCEAN AVENUE – BLOCK 19, LOTS 2 & 2.01
FOR THE 2024 SUMMER SEASON

Councilmember introduced and offered for adoption the following Resolution; seconded by
Councilmember :

WHEREAS, the Borough of Sea Bright recognizes the need to increase parking within the Borough of Sea Bright during the summer season to better serve the needs and convenience of residents and the general public; and

WHEREAS, the Borough of Sea Bright and JNM Holdings, Inc. have agreed to use the premises known as 1139 Ocean Avenue (Block 19, Lots 2 & 2.01) for additional parking pursuant to Chapter 130- 49F, " Temporary Uses," of the Code of the Borough of Sea Bright; and

WHEREAS, the Borough Administrator negotiated an agreement with JNM Holdings, Inc., attached hereto, outlining the terms and conditions for the use of 1139 Ocean Avenue; and

WHEREAS, the Borough Administrator proposed that the fee to park in said lot should be \$25.00 per day and all vehicles must be removed from the lot by 8:00 am the following day or will be subject to towing; and

WHEREAS, the Borough Council of the Borough of Sea Bright wish to enter into such an agreement, effective, nunc pro tunc, May 15, 2024, for the operation of a temporary municipal parking lot at the rate of \$25.00/per day.

NOW, THEREFORE, BE IT RESOLVED by the Borough Council of the Borough of Sea Bright, County of Monmouth, State of New Jersey that it does hereby authorize the Borough Administrator to execute an agreement with JNM Holdings, Inc. for the use of the parking lot at 1139 Ocean Avenue according to the terms and conditions in the attached agreement throughout the 2024 summer season; and

BE IT FURTHER RESOLVED that a certified copy of this Resolution be forwarded to the following:

1. Finance Manager
2. Beach Manager
3. Borough Attorney
4. JNM Holdings, Inc.
5. Police Department

Roll Call: Bieber, Catalano, Gorman, Keeler, Lamia, Leckstein

July 16, 2024

Certification

I, Christine Pfeiffer, Borough Clerk, do hereby certify the foregoing is a Resolution adopted by the Borough of Sea Bright, in the County of Monmouth, State of New Jersey, at a Council Meeting held on July 16, 2024.

Christine Pfeiffer, Borough Clerk

**2024 PARKING LOT AGREEMENT
WITH JNM HOLDINGS, INC.
BLOCK 19, LOTS 2 & 2.01 – 1139 OCEAN AVENUE**

FOR CONSIDERATION MUTUALLY EXCHANGED between JNM Holdings, Inc., 95 Avenue of Two Rivers, Rumson, New Jersey and the Borough of Sea Bright, this Agreement is made on this 20th day of June 2024.

WHEREAS, both parties originally entered into an Agreement on March 16, 2020 for the premises known as land which is designated as a portion of Block 19, Lots 2 & 2.01 on the Tax Map of the Borough of Sea Bright, at 1139 Ocean Avenue for parking and both parties desire to renew the Agreement for the 2024 summer season (May 15 through September 15).

BOTH PARTIES AGREE, as follows:

1. The Borough will staff and utilize the lots for paid parking.
2. The Borough will stripe and provide signage.
3. The Borough will provide additionally named insured language for insurance purposes.
4. The Borough will reserve 10 (ten) parking spots for Chapel Beach Club staff and/or patrons each day until 12:00 o'clock noon or until an agreed upon time of mutual consent.
5. The cost of agreed upon expenses will be shared by both parties.
6. The parties will split the net proceeds equally.
7. The Borough will also add to our final payment to JNM Holdings, Inc., an amount equal to four months taxes.

IN WITNESS WHEREOF, the parties have executed this agreement on the day and year first above written.

JNM Holdings, Inc.

Borough of Sea Bright

By: _____
Stephen Cutler

By: _____
Rachel Giolitto, Borough Administrator

RESOLUTION NO. 134-2024
**AUTHORIZING COMMUNITY DEVELOPMENT BLOCK GRANT
APPLICATION FOR ADA BATHROOM IMPROVEMENTS
IN THE BOROUGH COMMUNITY CENTER**

Councilmember _____ offered the following resolution and moved its adoption, which was seconded by Councilmember _____ :

WHEREAS, the County of Monmouth, Monmouth County Division of Planning for Community Development has notified all municipalities of the availability of funding under the Community Development Block Grant funding for the Fiscal Year 2025; and

WHEREAS, the Borough of Sea Bright is desirous of submitting an application under this program for the following purpose:

- ADA Bathroom Improvements, Borough Community Center (Original Municipal Building)

NOW, THEREFORE, BE IT RESOLVED by the Borough Council of Sea Bright, County of Monmouth, State of New Jersey, formally approves the grant application for the above stated project; and

FURTHER BE IT RESOLVED that the Borough Engineer, Mayor and Municipal Clerk are hereby authorized to submit an electronic grant application to the Monmouth County Division of Planning of Community Development; and

FURTHER BE IT RESOLVED that the Mayor and Municipal Clerk are hereby authorized to sign the grant agreement on behalf of the Borough of Sea Bright and that their signatures constitute acceptance of the terms and conditions of the grant agreement and approves the execution of the grant agreement.

ROLL CALL: Bieber, Catalano, Gorman, Keeler, Lamia, Leckstein

CERTIFICATION

I hereby certify that this is a true copy of a resolution passed by the Borough of Sea Bright Governing Body at their meeting held on July 16, 2024.

Christine Pfeiffer, RMC
Borough Clerk

My signature and the Clerk's seal serve to acknowledge the above resolution and constitute acceptance of the terms and conditions of the grant agreement and approve the execution of the grant agreement as authorized by the resolution above.

Attest and Affix Seal

Christine Pfeiffer, RMC
Borough Clerk

Brian P. Kelly
Mayor

**BOROUGH OF SEA BRIGHT
COUNTY OF MONMOUTH
STATE OF NEW JERSEY**

**RESOLUTION NO. 135-2024
AUTHORIZING GRANT APPLICATION TO NJDOT FOR FISCAL YEAR 2025**

Councilmember _____ offered the following resolution and moved its adoption, which was seconded
by Councilmember _____ :

WHEREAS, the State of New Jersey, Department of Transportation has notified all municipalities of the availability of funding under the Transportation Trust Fund Municipal Aid Program for the Fiscal Year 2025, and

WHEREAS, the Borough of Sea Bright is desirous of submitting an application under this program for the following purpose:

- Improvements to Beach Street, East Center Street, Wayne Street, and East Surf Street

NOW, THEREFORE, BE IT RESOLVED by the Borough Council of Sea Bright, County of Monmouth, State of New Jersey, formally approves the grant application for the above stated project; and

FURTHER BE IT RESOLVED that the Borough Engineer, Mayor and Municipal Clerk are hereby authorized to submit an electronic grant application identified as MA-2025-Beach Street, Wayne Street, East Cen-00313 to the New Jersey Department of Transportation on behalf of the Borough of Sea Bright; and

FURTHER BE IT RESOLVED that the Mayor and Municipal Clerk are hereby authorized to sign the grant agreement on behalf of the Borough of Sea Bright and that their signatures constitute acceptance of the terms and conditions of the grant agreement and approves the execution of the grant agreement.

Roll Call: Bieber, Booker, Catalano, Gorman, Keeler, Lamia

July 16, 2024

CERTIFICATION

I, Christine Pfeiffer, Borough Clerk, do hereby certify that the foregoing is a Resolution adopted by the Borough Council of the Borough of Sea Bright, County of Monmouth, State of New Jersey, at a Council Meeting held on July 16, 2024.

Christine Pfeiffer, Borough Clerk

My signature and the Clerk's seal serve to acknowledge the above resolution and constitute acceptance of the terms and conditions of the grant agreement and approve the execution of the grant agreement as authorized by the resolution above.

Attest and Affix Seal

Christine Pfeiffer, RMC
Borough Clerk

Brian P. Kelly
Mayor

RESOLUTION NO. 136-2024
RESCINDING SPECIAL CONDITION ON THE ALCOHOLIC BEVERAGE LICENSE
OF DONOVANS REEF INC. FOR THE 2024-2025 LICENSE TERM

Councilmember introduced and offered for adoption the following Resolution;
seconded by Councilmember :

WHEREAS, Donovan's Reef Inc. submitted a complete application form for the renewal of alcoholic beverage license no. 1343-33-007-004 and paid the annual fees to both the Borough of Sea Bright and the State of New Jersey, Division of ABC; and

WHEREAS, by way of Resolution No. 118-2024 on June 18, 2024, the Borough Council authorized the renewal of Donovan's Reef ABC license No. 1343-33-007-004 for the 2024-2025 term with the following two special conditions:

1. "No amplified live or recorded music shall be played in the outdoor portion of the licensed premises after 10:00 pm daily."
2. **"The drop-down garage doors shall be closed when amplified live or recorded music is being played inside of the licensed premises after 10:00 pm daily."**

WHEREAS, after further review, the Borough Council finds that special condition No. 2 should be rescinded.

NOW, THEREFORE, BE IT RESOLVED by the Borough Council of the Borough of Sea Bright, County of Monmouth, State of New Jersey, that the following special condition sanctioned on the renewal resolution No. 118-2024 is hereby rescinded:

"The drop-down garage doors shall be closed when amplified live or recorded music is being played inside of the licensed premises after 10:00 pm daily."

BE IT FURTHER RESOLVED that certified copies of this Resolution shall be forwarded to the following:

1. Chief of Police
2. Licensee
3. Division of Alcoholic Beverage Control

Roll Call: Bieber, Catalano, Gorman, Keeler, Lamia, Leckstein

July 16, 2024

CERTIFICATION

I, Christine Pfeiffer, do hereby certify that the foregoing is a resolution adopted by the Borough Council of the Borough of Sea Bright, County of Monmouth, State of New Jersey, at a Council Meeting held on July 16, 2024.

Christine Pfeiffer, Borough Clerk

RESOLUTION NO. 137-2024
GRACE PERIOD EXTENSION FOR PAYMENT OF
3RD QUARTER 2024 TAXES

Councilmember introduced and offered for adoption the following Resolution;
seconded by Councilmember :

WHEREAS, the Tax Collector has informed the Mayor and Borough Council that the Monmouth County Board of Taxation is delayed in forwarding necessary information for the preparation and mailing of final tax bills to the real estate taxpayers of the Borough of Sea Bright for the year 2024/2025; and

WHEREAS, the Borough Council has agreed that it would be unfair and unreasonable to impose a penalty for a delinquent payment when the amount of the payment is unknown.

WHEREAS, the present statute requires the imposition of a late charge if 3rd quarter 2024 taxes are not paid by the 10th of August; and

NOW, THEREFORE BE IT RESOLVED the Borough Council of the Borough of Sea Bright, County of Monmouth, State of New Jersey authorizes:

1. That the Tax Collector is hereby ordered and directed in accordance with Public Law 1994, Chapter 72, signed July 14, 1994, that if tax bills are not delivered or mailed at least 25 (twenty-five) calendar days prior to the standard due date, then the delinquency date for 3rd quarter 2024 taxes shall be established as the twenty-fifth (25) calendar days after the date the tax bill was delivered or mailed. The tax bills will contain the date on which interest shall start accruing.

BE IT FURTHER RESOLVED that a copy of this resolution be forwarded to the following:

1. Tax Collector

Roll Call: Bieber, Catalano, Gorman, Keeler, Lamia, Leckstein

July 16, 2024

CERTIFICATION

I, Christine Pfeiffer, do hereby certify that the foregoing is a resolution adopted by the Borough Council of the Borough of Sea Bright, County of Monmouth, State of New Jersey, at a Council Meeting held on July 16, 2024.

Christine Pfeiffer, Borough Clerk

RESOLUTION NO. 138-2024
REFUND OF PAYMENT ERROR
JUNIOR LIFEGUARD PROGRAM

Councilmember _____ introduced and offered for adoption the following Resolution seconded by Councilmember _____ :

WHEREAS, a payment was made in error for session one of the Sea Bright Junior Lifeguard Program by Jillian Werner in the amount of \$250.00; and

WHEREAS, the Tax Collector recommends that the payment be refunded accordingly; and

NOW, THEREFORE BE IT RESOLVED, that the Borough Council of the Borough of Sea Bright, County of Monmouth, State of New Jersey, does hereby authorize the Tax Collector and the Finance Manager to refund the said payment; and

BE IT FURTHER RESOLVED that a copy of this resolution be forwarded to the following:

1. Tax Collector
2. Finance Manager
3. Jillian Werner

Roll Call: Bieber, Catalano, Gorman, Keeler, Lamia, Leckstein

July 16, 2024

CERTIFICATION

I, Christine Pfeiffer, do hereby certify that the foregoing is a resolution adopted by the Borough Council of the Borough of Sea Bright, County of Monmouth, State of New Jersey, at a Council Meeting held on July 16, 2024.

Christine Pfeiffer, Borough Clerk

RESOLUTION NO. 139-2024
AUTHORIZING DISPLAY OF FIREWORKS
AT SANDS BEACH CLUB- AUGUST 20, 2024

Councilmember introduced and offered for adoption the following Resolution; seconded by Councilmember :

WHEREAS, N.J.S.A. 21:3-3 permits the governing body of a municipality to "grant a permit" for the public display of fireworks after application has been made in writing; and

WHEREAS, Sands Beach Club, 825 Ocean Avenue (Block 23; Lot 13) has submitted an application to the Special Events Committee of the Borough of Sea Bright requesting permission for a display of fireworks to be held at Sands Beach Club on August 20, 2024 (rain-date August 21, 2024); and

WHEREAS, such requests need to be approved by the Chief of Police, Fire Marshall and Special Events Committee of the Borough of Sea Bright, the US Fish and Wildlife Service and the NJ Division of Fish and Wildlife; and

WHEREAS, such displays shall be of such a character, and so located, discharged, or fired, as in the opinion of the Chief of Police and Fire Marshall, after proper inspection, shall not be hazardous to property or endanger any person or persons; and

NOW, THEREFORE, BE IT RESOLVED, by the Borough Council of the Borough of Sea Bright, County of Monmouth, that the request for a fireworks display is hereby approved for Sands Beach Club to be held on August 20, 2024 in accordance with approvals obtained from the above mentioned officials, the US Fish and Wildlife Service and the NJ Division of Fish and Wildlife; and

BE IT FURTHER RESOLVED that the Fire Official and Borough Clerk shall insure that all applicable regulations are enforced, all required permits are obtained and all necessary insurance documents are filed; and

BE IT FURTHER RESOLVED that a certified copy of this Resolution be forwarded to the following:

1. Sands Beach Club
2. Fire Official
3. Borough Police Chief
4. Special Events Committee
5. U.S. Fish and Wildlife Services

Roll Call: Bieber, Catalano, Gorman, Keeler, Lamia, Leckstein

July 16, 2024

CERTIFICATION

I, Christine Pfeiffer, do hereby certify that the foregoing is a resolution adopted by the Borough Council of the Borough of Sea Bright, County of Monmouth, State of New Jersey, at a Council Meeting held on July 16, 2024.

Christine Pfeiffer, Borough Clerk

RESOLUTION NO. 140-2024
CHAPTER 159 BUDGET AMENDMENT
STATE OF NEW JERSEY
FY2024 LOCAL RECREATION IMPROVEMENT GRANT

Councilmember _____ introduced and offered for adoption the following resolution; seconded by Councilmember _____ :

WHEREAS, N.J.S.A. 40A:4-87 provides that the Director of the Division of Local Government Services may approve the insertion of any special item of revenue in the budget of any county or municipality when such item shall have been made available by law and the amount was not determined at the time of the adoption of the budget; and

WHEREAS, said Director may also approve the insertion of an item of appropriation for an equal amount.

NOW, THEREFORE, BE IT RESOLVED that the Borough Council of the Borough of Sea Bright in the County of Monmouth, State of New Jersey, hereby requests the Director of the Division of Local Government Services to approve the insertion of an item of revenue in the budget of the year 2024 in the sum of \$35,000.00 which is now available as a revenue from the FY2024 **Local Recreation Improvement Grant** in the amount of \$35,000.00; and

BE IT FURTHER RESOLVED that the like sum of \$35,000.00 is hereby appropriated under the caption of **Local Recreation Improvement Grant**; and

BE IT FURTHER RESOLVED that the above is the result of funds awarded from the State of New Jersey Department of Community Affairs in the amount of \$35,000.00.

Roll Call: Bieber, Catalano, Gorman, Keeler, Lamia, Leckstein

July 16, 2024

CERTIFICATION

I, Christine Pfeiffer, Borough Clerk, do hereby certify that the foregoing is a resolution adopted by the Borough Council of the Borough of Sea Bright, County of Monmouth, State of New Jersey, at a Council Meeting held on July 16, 2024.

Christine Pfeiffer, Borough Clerk

RESOLUTION NO. 141-2024
AUTHORIZING RECEIPT OF BIDS
SOLID WASTE AND RECYCLABLE MATERIALS
COLLECTION SERVICE

Councilmember _____ introduced and offered for adoption the following
Resolution: seconded by Councilmember _____ :

WHEREAS, the Borough Council is desirous of receiving bids for the following:

- a) Solid Waste and Recyclable Materials Collection Services, and

WHEREAS, specifications for the aforesaid items will be on file in the Borough Clerk's Office, and will be available for inspection.

NOW, THEREFORE, BE IT RESOLVED by the Borough Council of the Borough of Sea Bright, County of Monmouth that it does hereby authorize the Borough Clerk to advertise for bids for the aforesaid item as per the specifications on file and will be received by the Borough Administrator in the Cecile F. Norton Community Center Meeting Room, 1099 Ocean Avenue, Sea Bright, New Jersey on a date to be determined.

BE IT FURTHER RESOLVED that a certified copy of this Resolution be forwarded to the following:

- 1. Finance Manager
- 2. Department of Public Works
- 3. Borough Attorney
- 4. Borough Engineer

Roll Call: Bieber, Catalano, Gorman, Keeler, Lamia, Leckstein

July 16, 2024

CERTIFICATION

I, Christine Pfeiffer, Borough Clerk, do hereby certify that the foregoing is a Resolution adopted by the Borough Council of the Borough of Sea Bright, County of Monmouth, State of New Jersey at a Council Meeting held on July 16, 2024.

Christine Pfeiffer, Borough Clerk

RESOLUTION NO. 142-2024
AUTHORIZING RECEIPT OF BIDS FOR THE
DPW BUILDING ON RIVER STREET

Councilmember introduced and offered for adoption the following Resolution:
seconded by Councilmember :

WHEREAS, the Borough Council is desirous of receiving bids for the following:

- a) DPW Building on River Street

WHEREAS, specifications for the aforesaid items will be on file in the Borough Clerk's Office, and will be available for inspection.

NOW, THEREFORE, BE IT RESOLVED by the Borough Council of the Borough of Sea Bright, County of Monmouth, State of New Jersey that it does hereby authorize the Borough Clerk to advertise for bids for the aforesaid item as per the specifications on file and will be received by the Borough on a date and time to be determined; and

BE IT FURTHER RESOLVED that a certified copy of this Resolution be forwarded to the following:

- 1. Finance Manager
- 2. Department of Public Works
- 3. CFO
- 4. Borough Engineer

Roll Call: Bieber, Catalano, Gorman, Keeler, Lamia, Leckstein

July 16, 2024

CERTIFICATION

I, Christine Pfeiffer, do hereby certify that the foregoing is a resolution adopted by the Borough Council of the Borough of Sea Bright, County of Monmouth, State of New Jersey, at a Council Meeting held on July 16, 2024.

Christine Pfeiffer, Borough Clerk

RESOLUTION NO. 143-2024
SETTING BID THRESHOLD AND APPOINTING
A QUALIFIED PURCHASING AGENT
BOROUGH OF SEA BRIGHT

Councilmember _____ introduced and offered for adoption the following Resolution; seconded by Councilmember _____ :

WHEREAS, N.J.S.A. 40A11-3a permits an increase in the bid and quote thresholds, up to \$44,000.00 and \$6,600.00 respectively, if a Qualified Purchasing Agent is appointed as well as granted the authorization to negotiate and award such contracts below the bid threshold; and

WHEREAS, N.J.A.C. 5:34-5 et seq., established criteria for qualifying as a Qualified Purchasing Agent; and

WHEREAS, the Borough Finance Manager, Kasey Kirschenbaum, possesses the designation and certification of Qualified Purchasing Agent as issued by the Director of the Division of Local Government Services in accordance with N.J.A.C. 5:34-5 et seq.; and

WHEREAS, the Borough of Sea Bright, in accordance with said law, wishes to increase its bid and quotation thresholds to \$44,000.00 and \$6,600.00 respectively.

WHEREAS, it would be in the best interest of the Borough to appoint the Borough Finance Manager, Kasey Kirschenbaum, to serve as the interim Qualified Purchasing Agent for the Borough of Sea Bright until such time as the Borough Administrator obtains QPA certification.

NOW, THEREFORE, BE IT RESOLVED by the Borough Council of the Borough of Sea Bright, County of Monmouth, State of New Jersey, does hereby designate Finance Manager, Kasey Kirschenbaum to serve as the interim Qualified Purchasing Agent for the Borough of Sea Bright effective immediately; and

BE IT FURTHER RESOLVED, that the Borough of Sea Bright bid and quote thresholds are increased to \$44,000.00 and \$6,600.00 respectively.

BE IT FURTHER RESOLVED that a certified copy of this resolution be forwarded to the following:

1. CFO
2. K. Kirschenbaum
3. Director, Division of Local Government Services

Roll Call: Bieber, Catalano, Gorman, Keeler, Lamia, Leckstein

July 16, 2024

CERTIFICATION

I, Christine Pfeiffer, Borough Clerk do hereby certify that the foregoing is a resolution adopted by the Borough Council of the Borough of Sea Bright, County of Monmouth State of New Jersey, at a Council Meeting held on July 16, 2024.

Christine Pfeiffer, Borough Clerk

ORDINANCE NO. 11-2024
**AN ORDINANCE AMENDING AND SUPPLEMENTING CHAPTER 178,
"SOLID WASTE," OF THE CODE OF THE BOROUGH OF SEA BRIGHT
TO ADD THERETO A NEW ARTICLE VII, "BULK ITEMS."**

BE IT ORDAINED by the Borough Council of the Borough of Sea Bright in the County of Monmouth, State of New Jersey, as follows:

SECTION ONE. Chapter 178, "Solid Waste," of the Code of the Borough of Sea Bright be and the same is hereby amended and supplemented to add thereto Article VII, "Bulk Items," to read, in full, as follows:

"Chapter 178. Solid Waste

Article VII. Bulk Items

§ 178-35 Definitions; word usage.

For the purpose of this article, the following terms, phrases, words, and their derivations shall have the meanings stated herein unless their use in the text of this article clearly demonstrates a different meaning. When not inconsistent with the context, words used in the present tense include the future, words used in the plural number include the singular number, and words used in the singular number include the plural number. The word "shall" is always mandatory and not merely directory.

BULK ITEMS

Bulk items shall include but not be limited to furniture, carpet, mattresses, bedding, household contents, pallets, pool covers and other larger items which are not easily containerized.

BUILDING MATERIALS

Any debris including fencing, decks, sheds, and all debris generated as a result of remodeling, demolishing or constructing homes or other buildings. Also includes by-products of clearing of land for the purpose of preparing the same for use as the site for a building or structure or for roadways or similar purposes.

APPLIANCES

White goods such as a washer, dryer, refrigerator, air conditioner, hot-water heater, stove, sink, tub, etc.

METALS

Any product which is made of completely or mostly a metal material.

§ 178-36 Bulk Items

Bulk items will be picked up on such dates as may be designated for such pickup. Bulk items are to be placed curbside in a neat and orderly fashion, not earlier than 7:00 p.m. the day before the scheduled pickup. No more than five (5) bulk items may be placed curbside for each collection. Building materials, appliances and metals will not be accepted.

§ 178-37 Enforcement.

The provisions of this article shall be enforced by the Sea Bright Police Department and Code Enforcement Officer.

§ 178-38 Violations and penalties.

Any person(s) who is found to be in violation of the provisions of this article shall be subject to a fine under the general penalty provisions.

SECTION TWO: All Ordinances or parts thereof inconsistent with the provisions of this Ordinance are hereby repealed to the extent of such inconsistencies.

SECTION THREE: If any section, subsection, paragraph, sentence or other portion of this Ordinance be adjudged by a Court of competent jurisdiction to be invalid, such judgment shall not affect, impair or invalidate the remainder of this Ordinance.

SECTION FOUR: This Ordinance shall take effect immediately upon its passage and publication as required by law.

I HEREBY CERTIFY this to be a true and correct Ordinance of the Mayor and Borough Council of the Borough of Sea Bright, introduced on June 18, 2024 and will be further considered after a Public Hearing held on July 16, 2024, in the Mayor Dina Long Community Room, 1097 Ocean Avenue, 7:00 pm.

INTRODUCED: June 18, 2024

PUBLIC HEARING: July 16, 2024

ADOPTED:

Witness

BOROUGH OF SEA BRIGHT

CHRISTINE PFEIFFER, CLERK

BRIAN KELLY, MAYOR

ORDINANCE NO. 12- 2024

AN ORDINANCE OF THE BOROUGH OF SEA BRIGHT AMENDING AND SUPPLEMENTING CHAPTER 130, "LAND USE", ARTICLE XVI, "STORMWATER CONTROL REGULATIONS" OF THE CODE OF THE BOROUGH OF SEA BRIGHT

BE IT ORDAINED by the Borough Council of the Borough of Sea Bright in the County of Monmouth, State of New Jersey, as follows:

Section I: Chapter 130, "Land Use", of the Code of the Borough of Sea Bright, Article XVI, "Stormwater Control Regulations," be and the same is hereby amended and supplemented to read, in full, as follows:

"Article XVI, Stormwater control regulations.

§130-91 Scope and Purpose.

A. Policy Statement

Flood control, groundwater recharge, and pollutant reduction shall be achieved through the use of stormwater management measures, including green infrastructure Best Management Practices (GI BMPs) and nonstructural stormwater management strategies. GI BMPs should be utilized to meet the goal of maintaining natural hydrology to reduce stormwater runoff volume, reduce erosion, encourage infiltration and groundwater recharge, and reduce pollution. GI BMPs should be developed based upon physical site conditions and the origin, nature and the anticipated quantity, or amount, of potential pollutants. Multiple stormwater management BMPs may be necessary to achieve the established performance standards for green infrastructure, water quality, quantity, and groundwater recharge.

B. Purpose

The purpose of this ordinance is to establish minimum stormwater management requirements and controls for "major development," as defined below in Section II.

C. Applicability

1. This ordinance shall be applicable to the following major developments:
 - i. Non-residential major developments and redevelopment projects; and
 - ii. Aspects of residential major developments and redevelopment projects that are not pre-empted by the Residential Site Improvement Standards at N.J.A.C. 5:21 et seq.
2. This ordinance shall also be applicable to all major developments undertaken by Borough of Sea Bright.
3. Applicability of this ordinance to major developments shall comply with last amended N.J.A.C. 7:8-1.6, incorporated herein by reference.

D. Compatibility with Other Permit and Ordinance Requirements

Development approvals issued pursuant to this ordinance are to be considered an integral part of development approvals and do not relieve the applicant of the responsibility to secure required permits or approvals for activities regulated by any other applicable code, rule, act, or ordinance. In their interpretation and application, the provisions of this ordinance shall be held to be the minimum requirements for the promotion of the public health, safety, and general welfare.

This ordinance is not intended to interfere with, abrogate, or annul any other ordinances, rule or regulation, statute, or other provision of law except that, where any provision of this ordinance imposes restrictions different from those imposed by any other ordinance, rule or regulation, or other provision of law, the more restrictive provisions or higher standards shall control.

Section II. Definitions:

For the purpose of this ordinance, the following terms, phrases, words and their derivations shall have the meanings stated herein unless their use in the text of this ordinance clearly demonstrates a different meaning. When not inconsistent with the context, words used in the present tense include the future, words used in the plural number include the singular number, and words used in the singular number include the plural number. The word "shall" is always mandatory and not merely directory. The definitions used in this ordinance shall be the same as the last amended Stormwater Management Rules at N.J.A.C. 7:8-1.2, incorporated herein by reference.

Section III. Design and Performance Standards for Stormwater Management Measures:

This section establishes design and performance standards for stormwater management measures for major development intended to minimize the adverse impact of stormwater runoff on water quality and water quantity and loss of groundwater recharge in receiving water bodies. Design and performance standards for stormwater management measures shall comply with last amended N.J.A.C. 7:8-5, incorporated herein by reference.

Section IV. Solids and Floatable Materials Control Standards:

- A. Site design features identified under Section III above, or alternative designs in accordance with Section III above, to prevent discharge of trash and debris from drainage systems shall comply with the following standard to control passage of solid and floatable materials through storm drain inlets. For purposes of this paragraph, "solid and floatable materials" means sediment, debris, trash, and other floating, suspended, or settleable solids. For exemptions to this standard see Section IV.A.2 below.

1. Design engineers shall use one of the following grates whenever they use a grate in pavement or another ground surface to collect stormwater from that surface into a storm drain or surface water body under that grate:

- i. The New Jersey Department of Transportation (NJDOT) bicycle safe grate, which is described in Chapter 2.4 of the NJDOT Bicycle Compatible Roadways and Bikeways Planning and Design Guidelines; or
- ii. A different grate, if each individual clear space in that grate has an area of no more than seven (7.0) square inches, or is no greater than 0.5 inches across the smallest dimension. Note that the Residential Site Improvement Standards at N.J.A.C. 5:21 include requirements for bicycle safe grates.

Examples of grates subject to this standard include grates in grate inlets, the grate portion (non-curb-opening portion) of combination inlets, grates on storm sewer manholes, ditch grates, trench grates, and grates of spacer bars in slotted drains. Examples of ground surfaces include surfaces of roads (including bridges), driveways, parking areas, bikeways, plazas, sidewalks, lawns, fields, open channels, and stormwater system floors used to collect stormwater from the surface into a storm drain or surface water body.

- iii. For curb-opening inlets, including curb-opening inlets in combination inlets, the clear space in that curb opening, or each individual clear space if the curb opening has two or more clear spaces, shall have an area of no more than seven (7.0) square inches, or be no greater than two (2.0) inches across the smallest dimension.

2. The standard in IV.A.1. above does not apply:

- i. Where each individual clear space in the curb opening in existing curb-opening inlet does not have an area of more than nine (9.0) square inches;
- ii. Where the municipality agrees that the standards would cause inadequate hydraulic performance that could not practicably be overcome by using additional or larger storm drain inlets;
- iii. Where flows from the water quality design storm as specified in the last amended Stormwater Management rules at N.J.A.C. 7:8 et seq. are conveyed through any device (e.g., end of pipe netting facility, manufactured treatment device, or a catch basin hood) that is designed, at a minimum, to prevent delivery of all solid and floatable materials that could not pass through one of the following:
 - a. A rectangular space four and five-eighths (4.625) inches long and one and one-half (1.5) inches wide (this option does not apply for outfall netting facilities); or

b. A bar screen having a bar spacing of 0.5 inches.

Note that these exemptions do not authorize any infringement of requirements in the Residential Site Improvement Standards for bicycle safe grates in new residential development (N.J.A.C. 5:21-4.18(b)2 and 7.4(b)1).

- iv. Where flows are conveyed through a trash rack that has parallel bars with one-inch (1 inch) spacing between the bars, to the elevation of the Water Quality Design Storm as specified in N.J.A.C. 7:8; or
- v. Where the New Jersey Department of Environmental Protection determines, pursuant to the New Jersey Register of Historic Places Rules at N.J.A.C. 7:4-7.2(c), that action to meet this standard is an undertaking that constitutes an encroachment or will damage or destroy the New Jersey Register listed historic property.

Section V. Safety Standards for Stormwater Management Basins:

A. This section sets forth requirements to protect public safety through the proper design and operation of stormwater management basins. This section applies to any new stormwater management basin. Safety standards for stormwater management measures shall comply with last amended N.J.A.C. 7:8-6, incorporated herein by reference.

B. Safety Ledge Illustration

Elevation View –Basin Safety Ledge Configuration

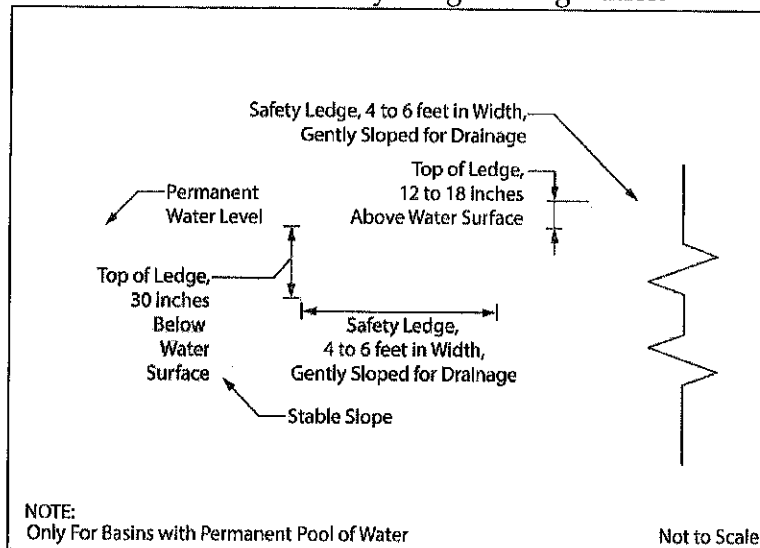

Section VI. Requirements for a Site Development Stormwater Plan:

A. Submission of Site Development Stormwater Plan

1. Whenever an applicant seeks municipal approval of a development subject to this ordinance, the applicant shall submit all of the required components of the Checklist for the Site Development Stormwater Plan at Section VI.C below as part of the submission of the application for approval.
2. The applicant shall demonstrate that the project meets the standards set forth in this ordinance.
3. The applicant shall submit three (3) copies of the materials listed in the checklist for site development stormwater plans in accordance with Section VI.C of this ordinance.

B. Site Development Stormwater Plan Approval

The applicant's Site Development project shall be reviewed as a part of the review process by the municipal board or official from which municipal approval is sought. That municipal board or official shall consult the municipality's review engineer to determine if all of the checklist requirements have been satisfied and to determine if the project meets the standards set forth in this ordinance.

C. Submission of Site Development Stormwater Plan

The following information shall be required:

1. Topographic Base Map

The reviewing engineer may require upstream tributary drainage system information as necessary. It is recommended that the topographic base map of the site be submitted which extends a minimum of 200 feet beyond the limits of the proposed development, at a scale of 1"=200' or greater, showing 2-foot contour intervals. The map as appropriate may indicate the following: existing surface water drainage, shorelines, steep slopes, soils, erodible soils, perennial or intermittent streams that drain into or upstream of the Category One waters, wetlands and flood plains along with their appropriate buffer strips, marshlands and other wetlands, pervious or vegetative surfaces, existing man-made structures, roads, bearing and distances of property lines, and significant natural and manmade features not otherwise shown.

2. Environmental Site Analysis

A written and graphic description of the natural and man-made features of the site and its surroundings should be submitted. This description should

include a discussion of soil conditions, slopes, wetlands, waterways and vegetation on the site. Particular attention should be given to unique, unusual, or environmentally sensitive features and to those that provide particular opportunities or constraints for development.

3. Project Description and Site Plans

A map (or maps) at the scale of the topographical base map indicating the location of existing and proposed buildings roads, parking areas, utilities, structural facilities for stormwater management and sediment control, and other permanent structures. The map(s) shall also clearly show areas where alterations will occur in the natural terrain and cover, including lawns and other landscaping, and seasonal high groundwater elevations. A written description of the site plan and justification for proposed changes in natural conditions shall also be provided.

4. Land Use Planning and Source Control Plan

This plan shall provide a demonstration of how the goals and standards of Section III is being met. The focus of this plan shall be to describe how the site is being developed to meet the objective of controlling groundwater recharge, stormwater quality and stormwater quantity problems at the source by land management and source controls whenever possible.

5. Stormwater Management Facilities Map

The following information, illustrated on a map of the same scale as the topographic base map, shall be included:

- i. Total area to be disturbed, paved or built upon, proposed surface contours, land area to be occupied by the stormwater management facilities and the type of vegetation thereon, and details of the proposed plan to control and dispose of stormwater.
- ii. Details of all stormwater management facility designs, during and after construction, including discharge provisions, discharge capacity for each outlet at different levels of detention and emergency spillway provisions with maximum discharge capacity of each spillway.

6. Calculations

- i. Comprehensive hydrologic and hydraulic design calculations for the pre-development and post-development conditions for the design storms specified in Section III of this ordinance.
- ii. When the proposed stormwater management control measures depend on the hydrologic properties of soils or require certain separation from the seasonal high water table, then a soils report shall be submitted. The soils report shall be based on onsite boring logs or soil pit profiles. The

number and location of required soil borings or soil pits shall be determined based on what is needed to determine the suitability and distribution of soils present at the location of the control measure.

7. Maintenance and Repair Plan

The design and planning of the stormwater management facility shall meet the maintenance requirements of Section VII.

8. Waiver from Submission Requirements

The municipal official or board reviewing an application under this ordinance may, in consultation with the municipality's review engineer, waive submission of any of the requirements in Section VI.C.1 through VI.C.6 of this ordinance when it can be demonstrated that the information requested is impossible to obtain or it would create a hardship on the applicant to obtain and its absence will not materially affect the review process.

Section VII. Maintenance and Repair:

A. Applicability

Projects subject to review as in Section I.C of this ordinance shall comply with the requirements of Section VII.B and VII.C.

B. General Maintenance

1. Maintenance for stormwater management measures shall comply with last amended N.J.A.C. 7:8-5.8, incorporated herein by reference.
2. In the event that the stormwater management facility becomes a danger to public safety or public health, or if it is in need of maintenance or repair, the municipality shall so notify the responsible person in writing. Upon receipt of that notice, the responsible person shall have fourteen (14) days to effect maintenance and repair of the facility in a manner that is approved by the municipal engineer or his designee. The municipality, in its discretion, may extend the time allowed for effecting maintenance and repair for good cause. If the responsible person fails or refuses to perform such maintenance and repair, the municipality or County may immediately proceed to do so and shall bill the cost thereof to the responsible person. Nonpayment of such bill may result in a lien on the property.

- C. Nothing in this subsection shall preclude the municipality in which the major development is located from requiring the posting of a performance or maintenance guarantee in accordance with N.J.S.A. 40:55D-53.

Section VIII. Penalties:

Any person(s) who erects, constructs, alters, repairs, converts, maintains, or uses any building, structure or land in violation of this ordinance shall be subject to a fine not to exceed \$1,000 per day for each day that the provisions of this article are violated. Each day that the provisions of this article are violated shall be deemed a separate offense. All violations of this article shall be prosecuted in the Municipal Court or any other tribunal with subject matter jurisdiction.

Section IX. Severability:

Each section, subsection, sentence, clause and phrase of this Ordinance is declared to be an independent section, subsection, sentence, clause and phrase, and the finding or holding of any such portion of this Ordinance to be unconstitutional, void, or ineffective for any cause, or reason, shall not affect any other portion of this Ordinance.

Section X. Effective Date:

This Ordinance shall take effect immediately upon its passage and publication according to law and upon filing with the Monmouth County Planning Board.

I HEREBY CERTIFY this to be a true and correct Ordinance of the Mayor and Borough Council of the Borough of Sea Bright, introduced on June 18, 2024 and will be further considered after a Public Hearing held on July 16, 2024 in the Municipal Building at 1097 Ocean Avenue at 7:00 p.m.

INTRODUCED: June 18, 2024

PUBLIC HEARING: July 16, 2024

ADOPTED:

Witness:

BOROUGH OF SEA BRIGHT

CHRISTINE PFEIFFER, CLERK

BRIAN P. KELLY, Mayor

BOND ORDINANCE NO. 13-2024
**BOND ORDINANCE PROVIDING AN APPROPRIATION
OF \$260,000 FOR VARIOUS ROAD IMPROVEMENTS FOR
AND BY THE BOROUGH OF SEA BRIGHT IN THE
COUNTY OF MONMOUTH, NEW JERSEY AND,
AUTHORIZING THE ISSUANCE OF \$50,500 BONDS OR
NOTES OF THE BOROUGH FOR FINANCING PART OF
THE APPROPRIATION.**

BE IT ORDAINED, BY THE BOROUGH COUNCIL OF THE BOROUGH OF SEA BRIGHT, IN THE COUNTY OF MONMOUTH, NEW JERSEY (not less than two-thirds of all members thereof affirmatively concurring) AS FOLLOWS:

SECTION 1:

The improvements described in Section 3 of this bond ordinance (the "Improvements") are hereby authorized to be undertaken by the Borough of Sea Bright, New Jersey (the "Borough") as general improvements. For the said Improvement there is hereby appropriated the amount of \$260,000, such sum includes the sum of \$209,500 expected to be received as a grant from the New Jersey Department of Transportation 2024 Municipal Aid Program. No down payment is required by the Local Bond Law of the State of New Jersey, constituting Chapter 2 of Title 40A of the New Jersey Statutes, as amended and supplemented (the "Local Bond Law") as the purpose authorized herein involve a project funded by a State grant from the New Jersey Department of Transportation as permitted under N.J.S.A. 40A:2-11c.

SECTION 2:

In order to finance the cost of the Improvements, negotiable bonds of the Borough are hereby authorized to be issued in the principal amount of \$50,500 pursuant to the provisions of the Local Bond Law (the "Bonds"). In anticipation of the issuance of the Bonds and to temporarily finance said improvements or purposes, negotiable bond anticipation notes of the Borough are hereby authorized to be issued in the principal amount not exceeding \$50,500 pursuant to the provisions of the Local Bond Law (the "Bond Anticipation Notes" or "Notes").

SECTION 3:

(a) The Improvements authorized and the purpose for the financing of which said obligations are to be issued is for various road improvements, including but not limited to the reconstruction of Via Ripa Way and South Way, and including curbing, drainage and other ancillary improvements, including all work and materials necessary therefor and incidental thereto, and as shown on and in accordance with the plans and specifications on file with the Borough Clerk.

(b) The estimated maximum amount of Bonds or Notes to be issued for the purpose of financing a portion of the cost of the Improvements is \$50,500.

(c) The estimated cost of the Improvements is \$260,000 which amount represents the initial appropriation made by the Borough.

SECTION 4:

All Bond Anticipation Notes issued hereunder shall mature at such times as may be determined by the chief financial officer of the Borough (the "Chief Financial Officer"); provided that no Note shall mature later than one year from its date. The Notes shall bear interest at such rate or rates and be in such form as may be determined by the Chief Financial Officer. The Chief Financial Officer shall determine all matters in connection with Notes issued pursuant to this ordinance, and the signature of the Chief Financial Officer upon the Notes shall be conclusive evidence as to all such determinations. All Notes issued hereunder may be renewed from time to time subject to the provisions of Section 8(a) of the Local Bond Law. The Chief Financial Officer is hereby authorized to sell part or all of the Notes from time to time at public or private sale and to deliver them to the purchasers thereof upon receipt of payment of the purchase price plus accrued interest from their dates to the date of delivery thereof. The Chief Financial Officer is directed to report in writing to the Borough Council of the Borough at the meeting next succeeding the date when any sale or delivery of the Notes pursuant to this ordinance is made. Such report must include the amount, the description, the interest rate and the maturity schedule of the Notes sold, the price obtained and the name of the purchaser.

SECTION 5:

The capital budget of the Borough is hereby amended to conform with the provisions of this ordinance to the extent of any inconsistency herewith. The resolution in the form promulgated by the Local Finance Board showing full detail of the amended capital budget and capital program as approved by the Director, Division of Local Government Services, Department of Community Affairs, State of New Jersey is on file with the Borough Clerk and is available for public inspection.

SECTION 6:

The following additional matters are hereby determined, declared, recited and stated:

(a) The Improvements described in Section 3 of this bond ordinance are not current expenses, and are capital improvements or properties that the Borough may lawfully make or acquire as general improvements, and no part of the cost thereof has been or shall be specially assessed on property specially benefited thereby.

(b) The period of usefulness of the Improvements, within the limitations of the Local Bond Law, and according to the reasonable life thereof computed from the date of the Bonds authorized by this bond ordinance, is 20 years.

(c) The Supplemental Debt Statement required by the Local Bond Law has been duly prepared and filed in the office of the Borough Clerk and a complete executed duplicate thereof has been filed in the office of the Director, Division of Local Government Services, Department of Community Affairs, State of New Jersey. Such statement shows that the gross debt of the Borough, as defined in the Local Bond Law, is increased by the authorization of the Bonds and Notes provided in this bond ordinance by \$50,500 and the obligations authorized herein will be within all debt limitations prescribed by the Local Bond Law.

(d) An aggregate amount not exceeding \$80,000 for items of expense listed in and permitted under Section 20 of the Local Bond Law is included in the estimated cost of the Improvements, as indicated herein.

SECTION 7:

Any funds received from time to time by the Borough as contributions in aid of financing the purposes described in Section 3 of this Ordinance shall be used for financing said Improvements by application thereof either to direct payment of the cost of said Improvements or to the payment or reduction of the authorization of the obligations of the Borough authorized therefor by this Bond Ordinance. Any such funds received may, and all such funds so received which are not required for direct payment of the cost of said Improvements shall, be held and applied by the Borough as funds applicable only to the payment of obligations of the Borough authorized by this Bond Ordinance.

SECTION 8:

The full faith and credit of the Borough are hereby pledged to the punctual payment of the principal of and interest on the obligations authorized by this bond ordinance. The obligations shall be direct, unlimited obligations of the Borough, and the Borough shall be obligated to levy ad valorem taxes upon all the taxable property within the Borough for the payment of the obligations and the interest thereon without limitation of rate or amount.

SECTION 9:

The Chief Financial Officer of the Borough is hereby authorized to prepare and to update from time to time as necessary a financial disclosure document to be distributed in connection with the sale of obligations of the Borough and to execute such disclosure document on behalf of the Borough. The Chief Financial Officer is further authorized to enter into the appropriate undertaking to provide secondary market disclosure on behalf of the Borough pursuant to Rule 15c2-12 of the Securities and Exchange Commission (the "Rule") for the benefit of holders and beneficial owners of obligations of the Borough and to amend such undertaking from time to time in connection with any change in law, or interpretation thereof, provided such undertaking is and continues to be, in the opinion of a nationally recognized bond counsel, consistent with the requirements of the Rule. In the event that the Borough fails to comply with its undertaking, the Borough shall not be liable for any monetary damages, and the remedy shall be limited to specific performance of the undertaking.

SECTION 10:

This Bond Ordinance constitutes a declaration of official intent under Treasury Regulation Section 1.150-2. The Borough reasonably expects to pay expenditures with respect to the Improvements prior to the date that Borough incurs debt obligations under this Bond Ordinance. The Borough reasonably expects to reimburse such expenditures with the proceeds of debt to be incurred by the Borough under this Bond Ordinance. The maximum principal amount of debt expected to be issued for payment of the costs of the Improvements is \$50,500.

SECTION 11:

This bond ordinance shall take effect 20 days after the first publication thereof after final adoption, as provided by the Local Bond Law.

I HEREBY CERTIFY this to be a true and correct Bond Ordinance No. 13-2024 of the Mayor and Borough Council of the Borough of Sea Bright, introduced on July 16, 2024, and will be further considered after a Public Hearing held on August 20, 2024, in the Mayor Dina Long Community Room, 1097 Ocean Avenue, at 7:00 pm.

INTRODUCED: July 16, 2024
PUBLIC HEARING: August 20, 2024
ADOPTED: , 2024

Witness

BOROUGH OF SEA BRIGHT,

CHRISTINE PFEIFFER, CLERK

BRIAN P. KELLY, MAYOR

**VOUCHER LIST
JULY 16, 2024
BOROUGH OF SEA BRIGHT**

3129	AB RICHARDS INC.		
	24-00702 06/17/24 Streets & Roads	Open	89.00
2703	ACTION UNIFORM CO.		
	24-00563 05/14/24 POLICE: MATERIALS & SUPPLIES	Open	1,411.30
00218	ALICE'S KITCHEN		
	24-00714 06/21/24 A&E	Open	626.00
02113	AMERICAN WATER		
	24-00783 07/10/24 SEWER: WATER USAGE	Open	328.52
2597	AT&T MOBILITY		
	24-00766 07/08/24 BEACH	Open	487.04
01957	BENEMAX BENEFIT MANAGEMENT CO.		
	24-00796 07/11/24 HEALTH BENEFITS	Open	1,032.00
01631	BOROUGH OF OCEANPORT		
	24-00719 06/24/24 COURT:SHARED SERVICE	Open	7,500.00
01731	CAESARS ATLANTIC CITY		
	24-00693 06/17/24 NJLOM Room Reservations	Open	1,660.00
2680	CINTAS		
	24-00164 02/06/24 Buildings & Grounds	Open	312.30
	24-00235 02/23/24 Buildings & Grounds	Open	424.04
	24-00326 03/13/24 Buildings & Grounds	Open	142.38
	24-00367 03/27/24 Buildings & Grounds	Open	142.38
	24-00689 06/17/24 Beach	Open	1,116.02
	24-00691 06/17/24 Buildings & Grounds	Open	1,252.25
	24-00740 07/02/24 Beach	Open	388.41

			3,777.78
00256	CLEARY, GIACOBBE, ALFIERI &		
	24-00768 07/09/24 LEGAL EXPENSES	Open	1,750.00
01801	COLLIER ENGINEERING & DESIGN		
	24-00329 03/13/24 ENGINEER	Open	2,967.50
3147	COMMUNITY GRANTS, PLANNING		
	24-00348 03/18/24 AFFORDABLE HOUSING	Open	346.50
01493	COOPERATIVE INDUSTRIES, L.L.C.		
	24-00722 06/24/24 NATURAL GAS	Open	1,375.37
02231	COUSINS LANDSCAPING		
	24-00524 05/08/24 BLDG & GRDS.	Open	5,583.33
00088	CROWN TIRE MART		
	24-00695 06/17/24 Streets & Roads	Open	480.00
02253	DAVID HODER ASSOCIATES		
	24-00779 07/10/24 ENGINEER FEES	Open	560.00
	24-00790 07/11/24 ESCROW FEES	Open	630.00

			1,190.00
2528	DCH FORD		
	24-00697 06/17/24 POLICE: VEHICLE MAINTENANCE	Open	842.27
2892	DOGWIG PRINTING		
	24-00489 04/25/24 UNIFORMS	Open	3,025.25
	24-00736 06/27/24 UNIFORMS	Open	1,824.50

			4,849.75
02240	DOOR WORKS, INC.		
	24-00233 02/23/24	Open	946.00

01754	EDMUNDS & ASSOCIATES, INC.		
24-00757	07/03/24 TAX BILLS BUNDLE	Open	37.00
2757	FIRE AND SAFETY SERVICES		
24-00588	05/21/24 Repairs to Tanker	Open	3,726.35
02101	GANNETT NY/NJ LOCALI-Q		
24-00725	06/24/24 PLANNING/ZONING BOARD	Open	5.72
24-00750	07/02/24 NOTICE BOND. ORD. 10-2024	Open	93.72

			99.44
02181	GATEWAY PRESS		
24-00701	06/17/24 POLICE: PRINTING & BINDING	Open	220.00
00979	GIBBONS, P.C.		
24-00749	07/02/24 BOND ORD LEGAL FEES	Open	475.00
02252	GRAINGER, INC.		
24-00644	06/05/24 POLICE: MATERIALS & SUPPLIES	Open	309.50
2710	HOLMDEL TOWNSHIP		
24-00720	06/24/24 FISCAL OFFICER	Open	3,656.34
01285	HOME DEPOT CREDIT SERVICES		
24-00751	07/02/24 DPW SUPPLIES	Open	236.55
3173	IMAGE 360		
24-00735	06/27/24 ENGRAVED NAMEPLATE	Open	17.00
01419	J. SWANTON FUEL OIL CO., INC.		
24-00734	06/26/24 GAS EXPENSES	Open	485.99
24-00781	07/10/24 GAS EXPENSES	Open	329.35

			815.34
3153	JAYADIT BUILDERS LLC		
24-00455	04/17/24 VIEWING PLATFORMS	Open	17,392.50
01526	JCP & L		
24-00795	07/11/24 ELECTRIC COSTS	Open	5,793.71
01784	JUNGLE LASERS, LLC		
24-00760	07/03/24 CONSTRUCTION/HOUSING DEPT.	Open	750.00
00202	KAY PRINTING & ENVELOPE CO, INC		
24-00659	06/11/24 BLDG DEPT	Open	100.68
2568	KELLY WINTHROP, LLC		
24-00244	02/23/24 Streets & Roads	Open	74.00
02110	KLEIN, DON		
24-00754	07/02/24 BEACH - DOLLY & SWIMMING FLAGS	Open	1,796.82
24-00755	07/02/24 MEMORIAL DAY EVENT SUPPLIES	Open	144.42

			1,941.24
2417	MARLIN BUSINESS BANK		
24-00753	07/02/24 POSTAGE METER FEES	Open	9.01
2278	MCLAUGHLIN, STAUFFER & SHAKLEE		
24-00762	07/03/24 LEGAL SERVICES - JUNE 2024	Open	17,134.61
3164	MERCER COUNTY FIRE ACADEMY		
24-00649	06/05/24 Fire Police Class	Open	100.00
3172	MICHELLE GRAHAM		
24-00732	06/26/24 RETIREMENT PARTY REIMBURSEMENT	Open	110.36
01967	MONMOUTH COUNTY PARK SYSTEM		
24-00573	05/16/24 BENCH	Open	140.00
02045	MONMOUTH COUNTY SPCA		
24-00717	06/24/24 ANIMAL CONTROL SERVICES	Open	400.00
01323	MONMOUTH COUNTY TREASURER		
24-00738	07/02/24 2024 PRIMARY BALLOTS POSTAGE	Open	144.59

00378	MONMOUTH TRUCK EQUIPMENT		
	24-00626 06/03/24 Streets & Roads	Open	190.48
3166	MORITZ EMBROIDERY WORKS, INC.		
	24-00637 06/04/24 BEACH	Open	284.00
00283	MUNICIPAL EMERGENCY SERV, INC.		
	24-00606 05/28/24 POLICE	Open	2,307.76
01399	NEW JERSEY AMERICAN WATER		
	24-00798 07/11/24 WATER EXPENSES	Open	5,674.97
3174	NICHOLAS R. SIMONS		
	24-00784 07/10/24 FIRE INSPECTOR FEES	Open	140.00
00113	NJ NATURAL GAS COMPANY		
	24-00724 06/24/24 NATURAL GAS	Open	83.53
02019	OMEGA GRAPHICS		
	24-00731 06/26/24 BEACH POSTERS	Open	310.00
00046	ONE CALL CONCEPTS, INC.		
	24-00759 07/03/24 SEWER	Open	31.46
02226	ORIGINAL WATERMEN		
	24-00712 06/21/24 BEACH	Open	9,345.34
01207	PFEIFFER, CHRISTINE		
	24-00733 06/26/24 RETIREMENT LUNCH REIMBURSEMENT	Open	562.92
2290	PORZIO, BROMBERG & NEWMAN		
	24-00761 07/03/24 LEGAL EXPENSES	Open	10,786.50
2300	PRECISION DYNAMICS CORP.		
	24-00586 05/20/24 BEACH	Open	3,231.60
3145	PRI MANAGEMENT GROUP		
	24-00354 03/27/24 POLICE: EDUCATION & TRAINING	Open	507.00
00164	RAIN, WILLIAM		
	24-00716 06/24/24 HEALTH INS/REIMB. MEDICARE B	Open	161.10
2728	READY REFRESH BY NESTLE		
	24-00780 07/10/24 WATER EXPENSES	Open	797.63
02141	RELIANCE GRAPHICS, INC.		
	24-00670 06/12/24 CLERK	Open	948.00
00463	RUTGERS, THE STATE UNIVERSITY		
	24-00730 06/26/24 CMFO COURSES - K. KIRSCHENBAUM	Open	2,340.00
	24-00737 07/01/24 QPA FALL COURSE - GIOLITTO	Open	944.00

			3,284.00
00985	SEABOARD FIRE/SAFETY EQUIP CO.		
	24-00696 06/17/24 Buildings & Grounds	Open	136.00
	24-00752 07/02/24 INSPECTION SERVICES	Open	1,235.00

			1,371.00
00027	SEABOARD WELDING SUPPLY, INC.		
	24-00765 07/08/24 OXYGEN/HAZMAT FEES	Open	18.50
00053	SHORE REGIONAL HIGH SCHOOL		
	24-00715 06/24/24 HIGH SCHOOL TAX: 2024-2025	Open	669,739.20
02225	STAPLES ADVANTAGE		
	24-00690 06/17/24 Office Supplies	Open	347.39
2535	SUBURBAN DISPOSAL, INC.		
	24-00791 07/11/24 TRASH	Open	9,577.33
	24-00792 07/11/24 DUMPSTERS & DISPOSAL	Open	3,995.70
	24-00793 07/11/24 TRASH EXPENSES	Open	23,001.86

			36,574.89

2574	TARGET SOLUTIONS LEARNING, LLC		
24-00707	06/18/24 BEACH	Open	849.40
00656	TAYLOR FENCE CO., INC.		
24-00789	07/11/24 2024 BEACH FIREWORKS FENCING	Open	2,421.20
00973	THE TWO RIVER TIMES		
24-00709	06/20/24 CLERK	Open	23.87
24-00764	07/08/24 AFFIDAVIT OF PUBLICATION	Open	4.34
24-00782	07/10/24 ADVERTISEMENT	Open	8.99

			37.20
01560	TOSHIBA BUSINESS SOLUTIONS, INC		
24-00699	06/17/24 POLICE: CONTRACTUAL SERVICES	Open	823.00
2884	TRAP ROCK INDUSTRIES, LLC		
24-00621	06/03/24 PARKING: MATERIALS & SUPPLIES	Open	2,997.92
01403	TREASURER, STATE OF NEW JERSEY		
24-00763	07/08/24 2024 2ND QTR LICENSES	Open	200.00
2457	UNITED STATES LIFESAVING ASSOC		
24-00713	06/21/24 BEACH	Open	1,000.00
00023	V. E. RALPH AND SON, INC.		
24-00631	06/04/24 BEACH	Open	3,210.00
02061	VERIZON WIRELESS		
24-00723	06/24/24 POLICE	Open	1,236.24
24-00794	07/11/24 CELL SERVICE	Open	197.65

			1,433.89
3171	WERNER, JILL		
24-00708	06/19/24 JR. LIFEGUARDS	Open	250.00

TOTAL: \$ 850,845.46

Manual Checks / Wire Transfers

24-00710	C.M.R.S.-FP (US POSTAL SERVICE)	\$607.00
6/20/2024	POSTAGE MACHINE REPLENISHMENT	
24-00711	VERIZON	\$335.29
6/20/2024	PHONE SERVICE	
24-00797	BORO OF SEA BRIGHT/EE' HEALTH	\$5,351.04
7/12/2024	BENEMAX REPLENISHMENT	
24-00721	BORO OF SEA BRIGHT CURRENT FUND	\$1,665.00
7/12/2024	T/F ADMINISTRATION FEES	

TOTAL: \$ 7,958.33

GRAND TOTAL: \$ 858,803.79